

# DEVELOPER GUIDE

## System Overview

The two-axis SCARA robotic arm draws a 10" straight line 4" per second to within an accuracy of .25" on an 8.5" x 11" sheet of paper. The robotic arm was to be inexpensive and manageable to manufacture as well as controlled by either G-Code commands via Graphical User Interface Device (GUI) or by a Human Interface Device (HID). The system was also designed to secure and use different types of writing tools (i.e. pen, pencil, crayon).

## User Guide

### 3D-Printed Enclosure Set Up

For set up, this section requires both the 3D-printed parts as well as the parts listed in the Enclosure Block bill of materials (BOM). For assembly, refer to Figures 5 and 6 for clarity. Assembly instructions:

1. Locate the STAND and TOWER of the 3D-printed parts. Locate two of the three steel rods. Insert the two steel rods through first the rod openings of the TOWER, through two nylon spacers, and finally into the two holes nearest to the PCB mounting platform on the STAND. The TOWER and STAND should now be secured upright with the two steel rods supporting the frame. The two nylon spacers act as buffers between the plastic of the STAND and TOWER to lessen friction due to movement of the robotic arm.
2. Prepare the UPPER BICEP, LOWER BICEP, SHOULDER, and PILLAR 3D-printed parts with ball bearings:
  - a. Affix one of the 6002rs ball bearings firmly into the larger sprocket opening of the UPPER BICEP. Affix the 608rs ball bearing firmly into the smaller sprocket opening of the UPPER BICEP.
  - b. Affix one of the 6002rs ball bearings firmly into the larger sprocket opening of the SHOULDER gear.
  - c. Affix the last 6002rs ball bearing firmly into the large sprocket opening of the LOWER BICEP. Affix the 623zz ball bearing into the small opening formed at one end of the LOWER BICEP with one M3 x 16mm screw.
  - d. Stack the following parts from bottom to top:
    - i. place the LOWER BICEP flat so the fully wide, flat side is flush with a flat work surface.
    - ii. Place one end of the long PILLAR into the center of the 6002rs ball bearing already affixed in the LOWER BICEP sprocket so that one end of the PILLAR is also now flush with the work surface.

- iii. Thread the SHOULDER gear with affixed ball bearing onto the long PILLAR sticking out of the LOWER BICEP.
    - iv. Thread the larger ball bearing hole of the UPPER BICEP onto the remaining length of the PILLAR.
    - v. Center the PILLAR across all of the parts so equal amounts of PILLAR are sticking out of the formed joint.
    - vi. Secure the UPPER BICEP to the LOWER BICEP with one M3 x 16mm screw. The circular formation in the middle of the LOWER BICEP should fit into the circular opening in the middle of the UPPER BICEP.
3. With the newly formed joint in hand, thread the one remaining steel rod through the remaining hole opening of the TOWER and into the PILLAR hole opening. Push the steel rod into the last hole opening of the STAND, securing the BICEP/SHOULDER/PILLAR joint between the STAND and the TOWER.
4. Prepare the FOREARM:
  - a. Thread the end-thread bolt first through the larger sprocket side of the FOREARM and out through the flat side of the FOREARM hole. Thread the metal washer onto the end-thread bolt so the washer is placed flush to the flat side of the FOREARM.
  - b. Thread the rest of the end-thread bolt through the ball bearing hole in the underside of the UPPER BICEP. The 623zz ball bearing on the LOWER BICEP should now be sitting flush to the side of the smooth edge of the sprocket on the FOREARM.
  - c. Secure the M8 nut onto the end-thread bolt sticking out of the UPPER BICEP ball bearing.
5. Affix both nema 17 motors onto the TOWER platform with eight M3 x 10mm motor screws. The motors should be affixed as close to the direction of the arm as possible. This placement will later help to tighten the timing belts in step 7. The motor shaft should be placed through the large holes of the motor platform so the shafts are pointing down to the work surface.
6. Affix the two metal timing pulleys to the motor shafts: One timing pulley should be placed with the thicker side up onto the left motor shaft. The other timing pulley should be placed with the thicker side down onto the right motor shaft.
7. Prepare the timing belts:
  - a. Extend a length of the timing belt around the UPPER BICEP sprocket, to the left (Motor\_2) motor's timing pulley, and back to the UPPER BICEP sprocket. With the length of timing belt estimated, gorilla glue the belt in place and set the seam with a firm clasp until dry. To dry, the seam should be wiped of extra glue and not be over any other part to avoid glueing the belt to a static part.
  - b. Extend a length of the timing belt around the upper SHOULDER sprocket, to the right (Motor\_1) motor's timing pulley, and back to the upper SHOULDER sprocket. With the length of timing belt estimated, gorilla glue the belt in place and set the seam with a firm clasp until dry. To dry, the seam should be wiped of extra glue and not be over any other part to avoid glueing the belt to a static part.

- c. Extend a length of the timing belt around the lower SHOULDER sprocket, to the FOREARM sprocket, and back to the lower SHOULDER sprocket. With the length of timing belt estimated, gorilla glue the belt in place and set the seam with a firm clasp until dry. To dry, the seam should be wiped of extra glue and not be over any other part to avoid glueing the belt to a static part.
  - d. After the glue is dry, untighten the screws mounting the motors, pull the motors slightly back from the BICEP sections to tighten the belts, and retighten the motor screws to secure the motors.
8. Affix the stand to a flat working surface of choice with six large M8 x 8mm screws . This surface will be the surface that an 8.5” by 11” sheet of paper will be affixed to for the robotic arm to draw a line.
9. Affix the PCB onto the STAND’s PCB mounting platform with two to four M3 x 6mm screws and nylon mounting pillars.

### **End Effector Set Up**

1. Insert the servo into the End Effector Body
2. Fasten the screw in the left claw to the mounting hole in the servo.
3. Connect the Servo’s power wire to an available 5V Power Pin on the Arduino UNO
4. Connect the Servo’s ground wire to an available GND port on the Arduino UNO’s power pins.
5. Connect the Servo’s signal wire to Digital Pin 9

### **Motor Driver Set up**

1. Insert the Motor Driver carrier boards into the two 8 position female header pin rows so that the potentiometer on the carrier board is close to the EN pin.
2. Connect the SLP/RST on the pins to the 5V POWER pins on the Arduino UNO.
3. Check the current limit by measuring the reference voltage between each carrier board’s potentiometer and ground pin.
  - a. Looking at the carrier board with the potentiometer in the top left corner, the ground pin is the bottom right-most pin.
  - b. Power the board for the duration of this step by connecting the wall adapter to the barrel jack.
  - c. Adjust the potentiometer so the voltage between the potentiometer and ground is about 0.50V
  - d. Repeat 3a through 3c for the other carrier board.
  - e. Remove power from the board by disconnecting the wall adapter from the barrel jack.
4. Connect DIR and STEP pins on the Motor Driver Board to the appropriate Arduino UNO Digital pins.

- a. Elbow Motor (Motor\_1 label on the Motor Driver Board) DIR connects to Digital Pin 9, Motor 1 STEP connects to Digital Pin 10
  - b. Shoulder Motor DIR connects to Digital Pin 4, Motor 2 STEP connects to Digital Pin 5
5. Connect the Motor outputs on the board to the Nema-17 stepper motors.
    - a. Note: The Nema-17 motors have 2 coils inside of them with 1 coil using 2 pins. Both motor connection points on the board will connect the coils appropriately, as long as the motors are connected properly with the Blue wire on board pin B2.
  6. Insert power adapter connector into the Barrel Jack on the Motor Driver Board.

## Controlling the Robotic Arm

Install the Arduino IDE for your operating system at <https://www.arduino.cc/en/main/software>. Plug the Arduino UNO into the computer via USB cable. Open the control code in the Arduino IDE and upload it to the Arduino UNO. Ensure the steps in the “Motor Driver Set Up” section of this User Guide are completed so the motor driver and PCB board are connected to the two nema 17 stepper motors. The two methods of controlling the robotic arm (1. G-Code commands using the Qt Creator GUI or 2. Gaming Controller) are described as follows:

To operate the robotic arm by G-Code commands using the Qt Creator GUI, follow the instructions:

1. Install Qt Creator at <https://www.qt.io/>. Open the GUI code in Qt Creator and run the program. Choose a G-Code command. The description of the G-Code will be displayed on the terminal. Enter the X and Y coordinates to send the utensil to the desired location.
  - a. The X and Y coordinates are relative to the X-Y plane of the paper. In this system, the origin has been set to the bottom middle of the paper, for both landscape and portrait orientation.
    - i. The default orientation of the paper is landscape. The orientation can be changed in the control code by setting the variable ‘mode\_orientation’ to ‘l’ for landscape or ‘p’ for portrait.
    - ii. The default unit of the system is metric. The unit can be set to inches by executing G20, or to millimeters by executing G21.
  - b. The system has two operating modes: absolute mode or incremental mode.
    - i. If the system is in absolute mode, either by default or by executing G90 in the GUI, the entered coordinates are relative to the origin of the paper.
    - ii. If the system is in incremental mode, by executing G91 in the GUI, the user entered coordinates are relative to the current position of the utensil.
2. Press the execute button to have the system perform the command.

To operate the robotic arm by using a human interface device (HID), refer to Figure 4 and follow the instructions:

1. The gaming controller:
  - a. If using an Xbox controller, skip to step 2.
  - b. Plug the PS3 gaming controller via USB into your computer.
2. Install the Keysticks software for your operating system at <https://keysticks.net/download.aspx>.
  - a. Format Keysticks to your computer's keyboard as seen in Figure 1. To format, select the "edit the current profile button". Right click the desired key, hover over "type key", hover over "letter key", and select the desired letter.



*Figure 1. Keysticks Layout*

- b. In Keysticks, select "edit the current profile" and edit each button to "auto repeat".
    - c. Under the "Settings" tab in the "edit the current profile" page, change the left stick, right stick, left trigger, and right trigger "Hold/Auto Repeat" setting down to the lowest available, which is 0.2 seconds, for both Hold and Auto Repeat.
    - d. Before leaving the "edit the current profile" page, select "Apply" and then "OK".
3. Install PuTTY for your operating system at <https://www.puttygen.com/download-putty>.
4. Before using the HID, open PuTTY and select "serial port". Change the communication port to the com-port that your gaming controller USB is connected to. Select the "load" button followed by the "open" button.

## Electrical Specifications

INTERFACE DEFINITIONS		
Interface Name	Interface Type	Specifics
user_input	Input	User device input
g_code	Code	g_code is a command with coordinates transmitted over serial port from Qt GUI. Language: G-code
control_code	Code	Arduino UNO IDE Reads and interprets G-codes Motor control algorithms Code size: 32 kB
HID_signal	Digital Signal	$V_{Max}$ : 5 V $I_{Max}$ : 450 mA
motor_signal	Digital Signal	PWM 1/32 Microstepping Stepper $V_{Range}$ : 8.25 - 45 V $I_{Max}$ : 2.5 A
motor_pwr	DC Power	Torque: 0.48 Nm Steps/Revolution: $200 \pm 5\%$ $V_{Range}$ : 12 - 48 V DC $I_{Max}$ : 2 A rms Ambient Temperature: 14 F-122F
servo_pwr	DC Power	$V_{Range}$ : 2- 5 V $I_{Nominal}$ : 4.5 V $I_{No Load}$ : 0.058 A $I_{Max}$ : 0.0184 A Power Rating: 0.386 W Torque: 3.93 g-cm
servo_signal	Digital Signal	PWM
output_draw_line	Output	Drawn line on paper

Table 1. Interface Definitions

# Block Diagram

Power to the motors (motor\_pwr) is input to two DRV8825 bipolar stepper motor drivers which take a minimum voltage of 12 V DC to a maximum voltage of 48 V DC with a maximum current of 2 A. The software that drives the arm (control\_code) is an arduino sketch that runs on an Arduino UNO/Clone UNO. This code drives the motors through the motor driver. The servo interfaces with the Arduino directly, and does not connect to the motor driver board.

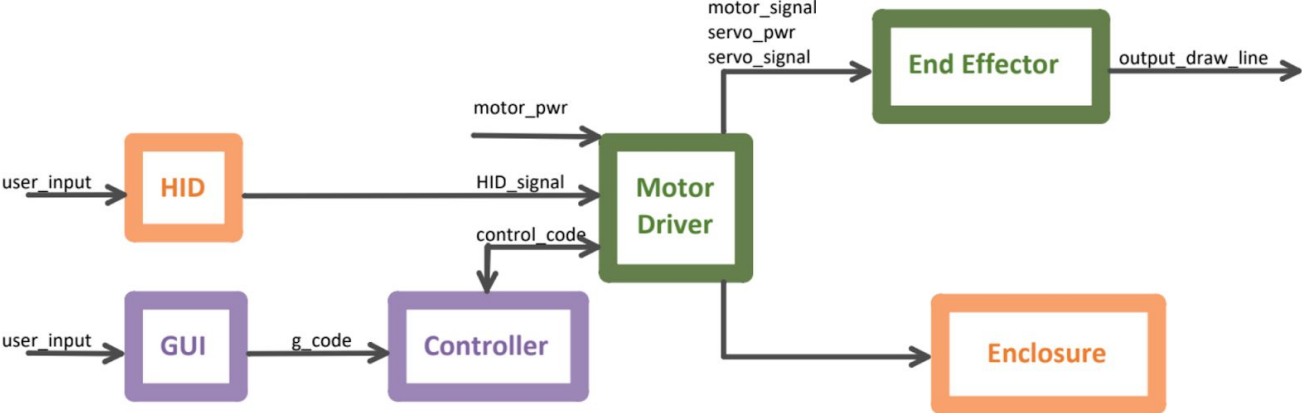

**BLOCK LEGEND**  
Ashley Osburn  
Will Otos  
Nicole Dean

Figure 2. Block Diagram

## Schematic

The Motor Driver takes 12 - 48V DC into the barrel jack and passes signals from the Arduino UNO to the stepper motors. The carrier boards that the DRV8825 Stepper motor drivers are mounted to make use of components that leave them vulnerable to voltage spikes from the power supply. The capacitor in between the Driver's voltage input and ground keeps the drivers safe by filtering out sudden spikes in voltage.

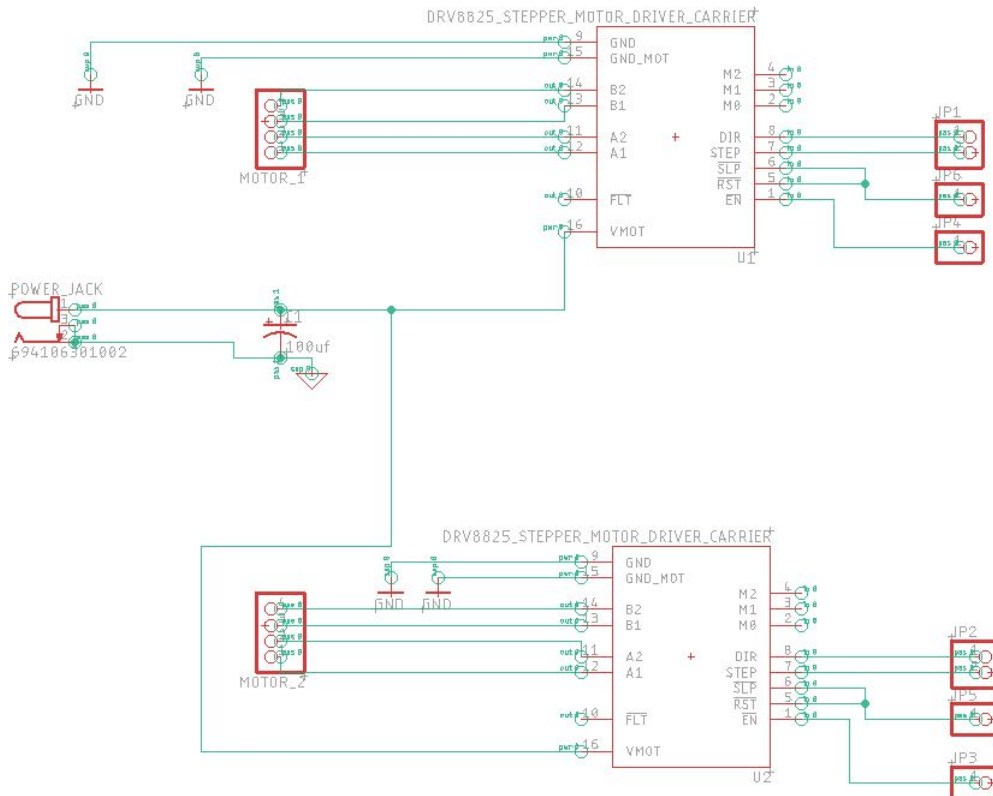

Figure 3. Motor Driver Schematic



## Wiring Diagram (HID Block)

The gaming controller buttons are mapped to the computer's keyboard via the software KeySticks. PuTTY sends keys from the keyboard through a serial port to the Arduino UNO. To move the robotic arm, the Arduino sends pulses to the motor drivers on the PCB, and thus the motors.

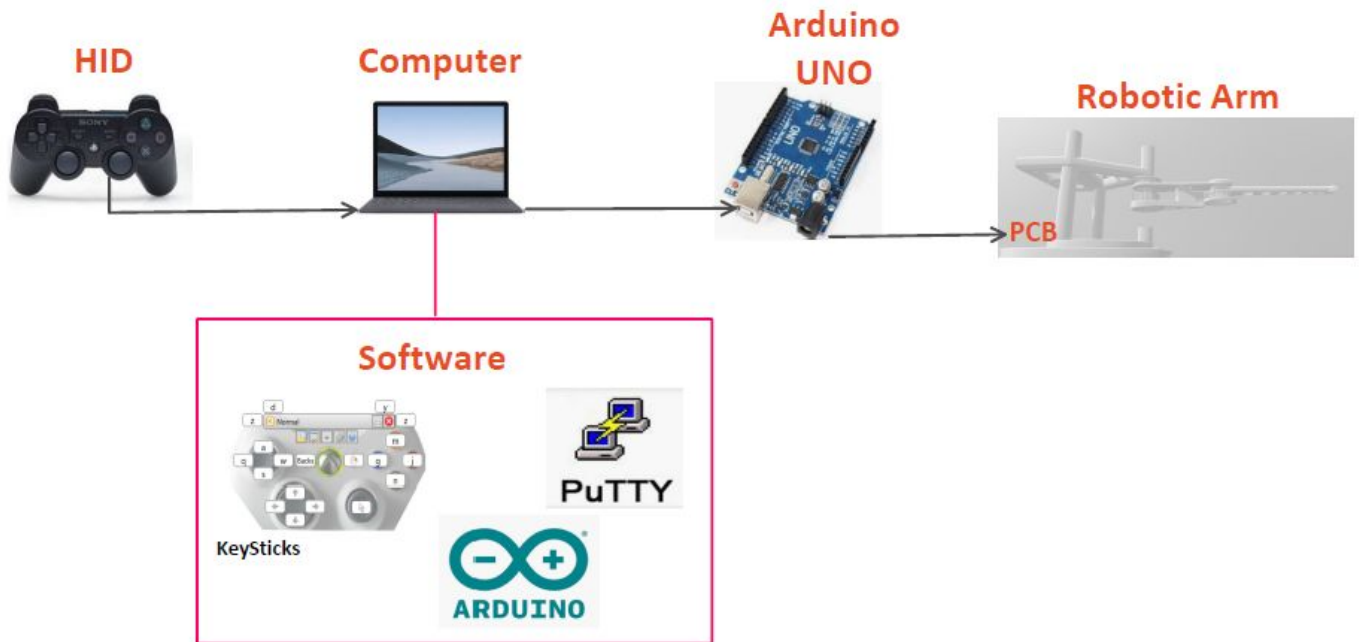
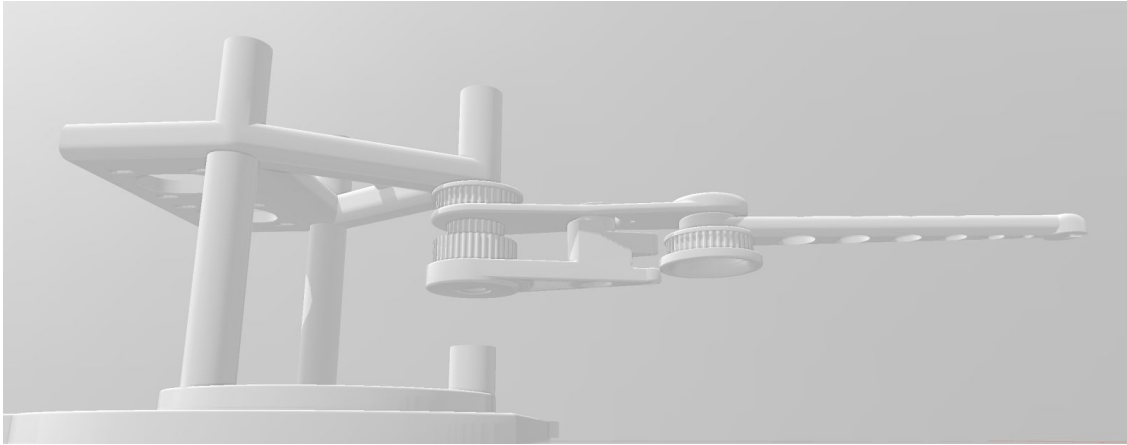

Figure 4. Wiring Diagram for HID Block

## 3D Model



*Figure 5. Robotic Arm 3D Model*

The SCARA two-axis robotic arm consists of seven 3D-printed parts: the stand, tower, pillar, shoulder gear, upper bicep, lower bicep, and forearm (*Figure 6*). The 3D-printed arm was designed using as few total parts as possible while maintaining function, lightness, and strength. The attractive design includes a PCB mounting platform on the stand, a platform to mount two nema 17 stepper motors on the tower, and multiple wire-securing points-of-access to minimize loose wires on the tower, forearm and bicep parts. The arm has a maximum reach length of 10.82 inches (0.275 meters). The robot is made to mount on any flat surface using six bolt holes in the stand's base.

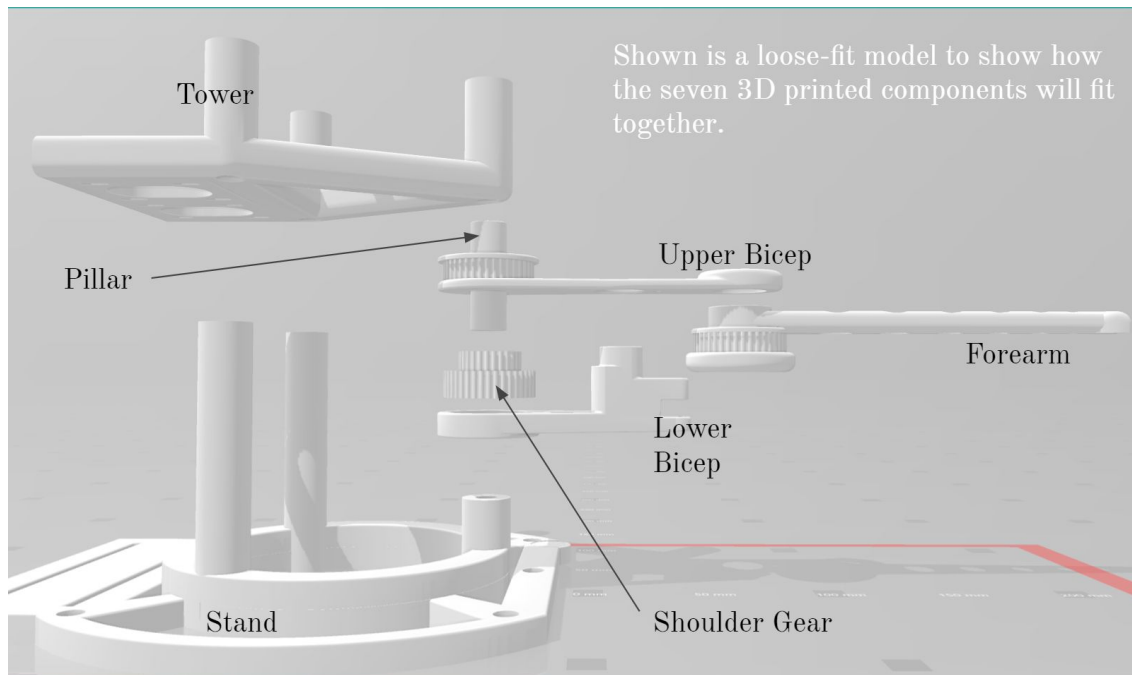

*Figure 6. Robotic Arm Labeled Parts*

## PCB information

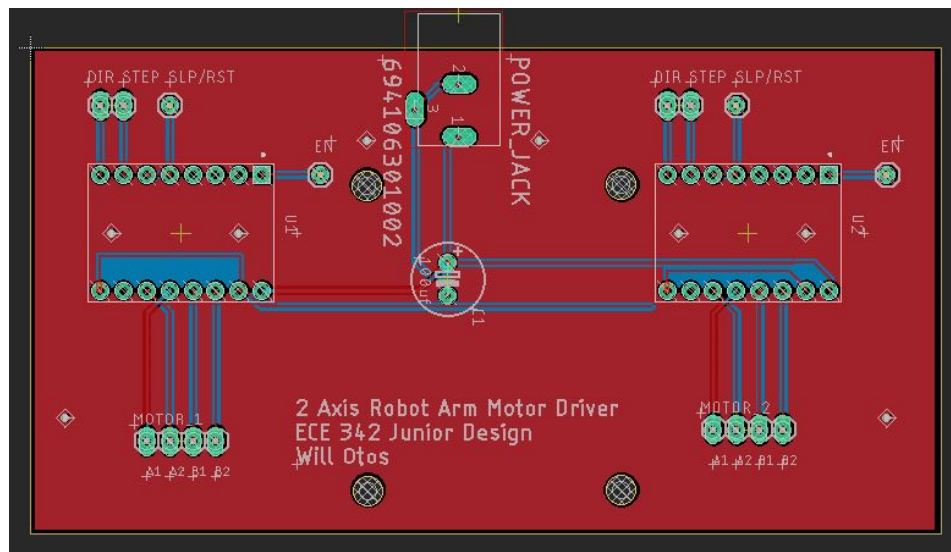

Figure 7. Motor Driver PCB Layout

Board Dimensions: 50mm x 100mm

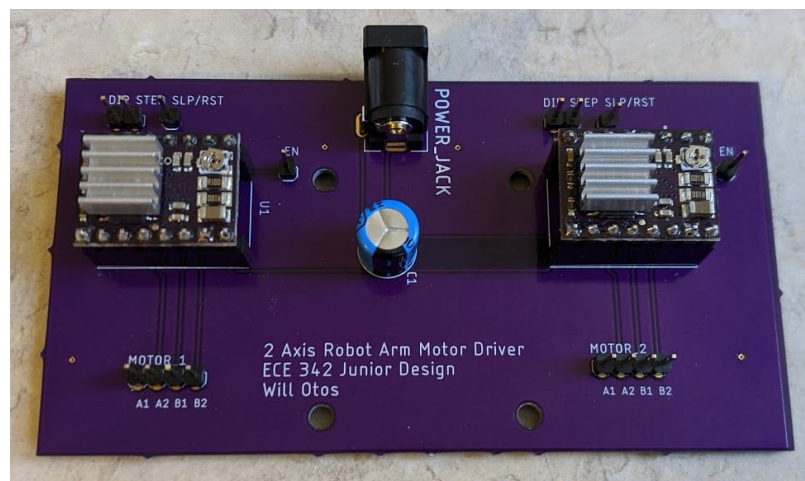

Figure 8. Motor Driver PCB with carrier boards installed

## Project Bill of Materials (BOM)

#	Description	Part	References	Value	Extended Cost	Cost	Quantity	Manufacturer	MPN	Supplier
1	Steel Rods	Rod	Steel Rod	8mm x 200mm	\$11.40	\$3.80	3	Edmunds Scienti	1119330	<a href="http://usa.Banggood.com">usa.Banggood.com</a>
2	3D Printed Arm	Body	Enclosure	na	specified on Tek	na	1	Tekbots	na	personal
3	Tiny Bearings	Ball Bearing	Bearing	623zz	\$0.20	\$0.20	1	MACHIFIT	1049663	<a href="http://usa.Banggood.com">usa.Banggood.com</a>
4	Rubberized ball b	Ball Bearing	Bearing	6002rs	\$3.87	\$1.29	3	PGN Bearings	6002-2RS	PGN Bearings
5	Rubberized ball b	Ball Bearing	Bearing	608rs	\$0.49	\$0.49	1	PGN Bearings	608-2RS	PGN Bearings
6	Motor pulley tim	Belt	Timing Belt	3GT (GT2-3M), 5	\$10.47	\$3.49	3 ft	not listed	819368021790	<a href="http://OpenBuildsPartStore.com">OpenBuildsPartStore.com</a>
7	Motor pulley cap	Pulley	Timing Pulley	GT3 5mm bore, 1	\$1.32	\$0.66	2	linc cnc	GT3	<a href="http://AliExpress.com">AliExpress.com</a>
8	motor mount scr	Screw	Motor screws	M3 x 10mm	\$0.56	\$0.07	8	unknown	842176120355	<a href="http://Fastenere.com">Fastenere.com</a>
9	Stand-to-tower r	Spacer	Nylon Spacer	M8 - 5/16"	\$0.72	\$0.24	3	unknown	unknown	Walmart
10	Bolts stand to su	Screw	Stand screws	M8 x 8mm	\$0.42	\$0.42	6	unknown	842176176802	<a href="http://Fastenere.com">Fastenere.com</a>
11	PCB fixing screws	Screw	PCB screws	M3 x 6mm	\$0.28	\$0.07	4	unknown	842176120379	<a href="http://Fastenere.com">Fastenere.com</a>
12	nylon PCB moun	Pillar	PCB pillar spacer	M3 X 8mm	\$1.56	\$0.13	12	Waltfront	Waltfront-05103	<a href="http://Amazon.com">Amazon.com</a>
13	Secures tiny Ball	Screw	Lower Bicep bea	M3 x 16mm	\$0.18	\$0.09	2	Jing Long	KA3X16	<a href="http://moddiy.com">moddiy.com</a>
14	Secures elbow hi	End-Thread Bol	Elbow hinge	M8 x 45mm	\$0.62	\$0.62	1	unknown	842176119991	<a href="http://Fastenere.com">Fastenere.com</a>
15	Slick spacer for e	Washer	Metal Spacer	1/4 in	\$0.05	\$0.05	1	unknown	unknown	<a href="http://bridgefasteners.com">bridgefasteners.com</a>
16	Elbow bolt's nut	Nut	Elbow nut	M8	\$0.19	\$0.19	1	unknown	84217616636	<a href="http://Fastenere.com">Fastenere.com</a>
17	Gaming Controlle	HID	Gaming Controlle	PS3	\$44.99	\$44.99	1	Sony	PS3	<a href="http://amazon.com">amazon.com</a>
18	DRV8825	Stepper Motor (	U1, U2	Bipolar Stepper	\$20.90	\$10.45	2	Pololu	2183-2982-ND	DigiKey
19	694106301002	Power Jack	POWER_JACK	DC Power Jack	\$0.96	\$0.96	1	Würth Elektronik	490-9956-1-ND	DigiKey
20	SMC-1-08-1-GT	Connector	U1, U2	8-Pin Female Co	\$2.60	\$0.65	4	Sullins Connecto	S7006-ND	DigiKey
21	61300411121	Connector	MOTOR_1, MOT	4-Pin Male Conn	\$1.08	\$0.18	6	Würth Elektronik	732-5317-ND	DigiKey
22	61300211121	Connector	DIR, STEP	2-Pin Male Conn	\$0.26	\$0.13	2	Würth Elektronik	732-5315-ND	DigiKey
23	61300111121	Connector	SLP/RST, EN	1-Pin Male Conn	\$0.52	\$0.13	4	Würth Elektronik	732-5314-ND	DigiKey
24	UHE1H101MPD	Capacitor	C1	100uF	\$0.45	\$0.45	1	Nichicon	493-1605-ND	DigiKey
25	L6R18-120	Power Supply	Wall Adapter	N/A	\$8.60	\$8.60	1	Tri-Mag, LLC	364-1271-ND	DigiKey

Table 2. Project Bill of Materials